

## ◆ Parallel Arm Mounting

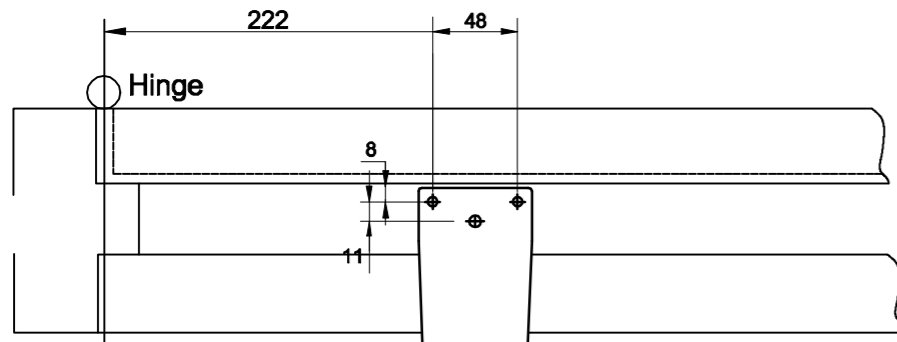

Right hand door illustrated same dimensions apply to left hand door.  
Measured from hinge center.  
Dimensions are in mm

**NOT TO SCALE:**

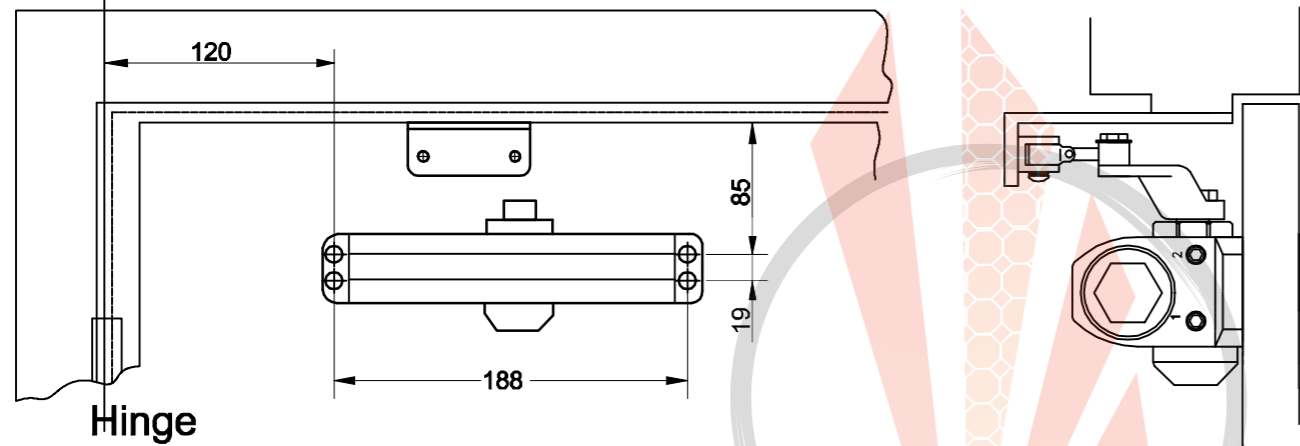

### Installation Sequences:

- Select opening degree of the door. Drill mounting holes on door leaf and frame in accordance with above shown dimensions.
- Mount the door closer body to door leaf with speed regulating valve back to hinge.
- Attach parallel arm plate to top frame as shown.
- Remove foot from forearm as shown and discard it.
- Install main arm on pinion shaft, rotate pinion 45° towards hinge edge of door to align main arm letter "B" (right and door) or "A" (left hand door) with pinion flat. Fasten with arm screw.
- Fasten forearm to parallel arm plate.
- Adjust forearm length to set the arm elbow about 1-1/2" (38mm) from door when connected to main arm. Use washer and screw provided to secure pivot connection. Tighten locknut.
- Adjust closer.

# ARTICA DCOH-85 SERIES DOOR CLOSER

## INSTALLATION INSTRUCTIONS

### Installation Sketches:

EN:4

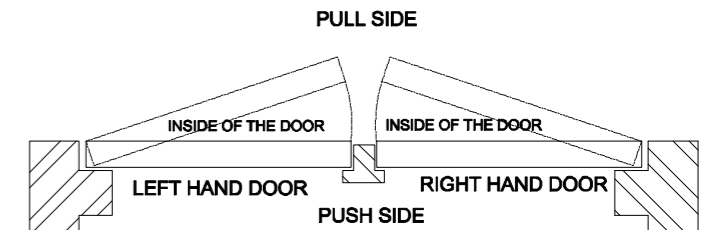
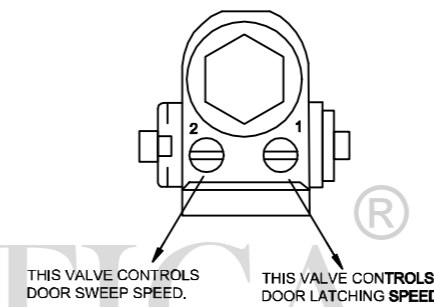
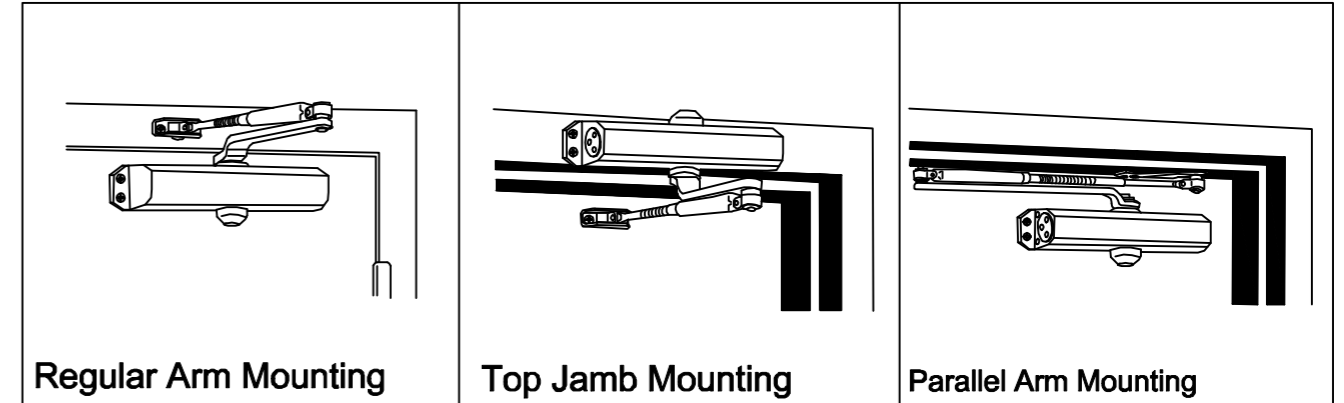

### CLOSING SPEED CONTROL

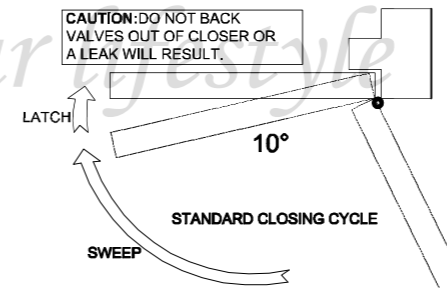

For Door Weight: 60-85KGS

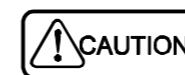

- NOTE:
- DOOR CLOSER HAS THE FUNCTION TO CLOSE THE DOOR AUTOMATICALLY; NO EXTRA FORCE IS EXERTED, OTHERWISE THE CLOSER MAY BE DAMAGED.
  - WE WON'T BE RESPONSIBLE FOR ANY DAMAGE BECAUSE OF WRONG MOUNTING WAY AND DIMENTION WHICH IS NOT IN CONFORMITY WITH THIS INSTRUCTION.

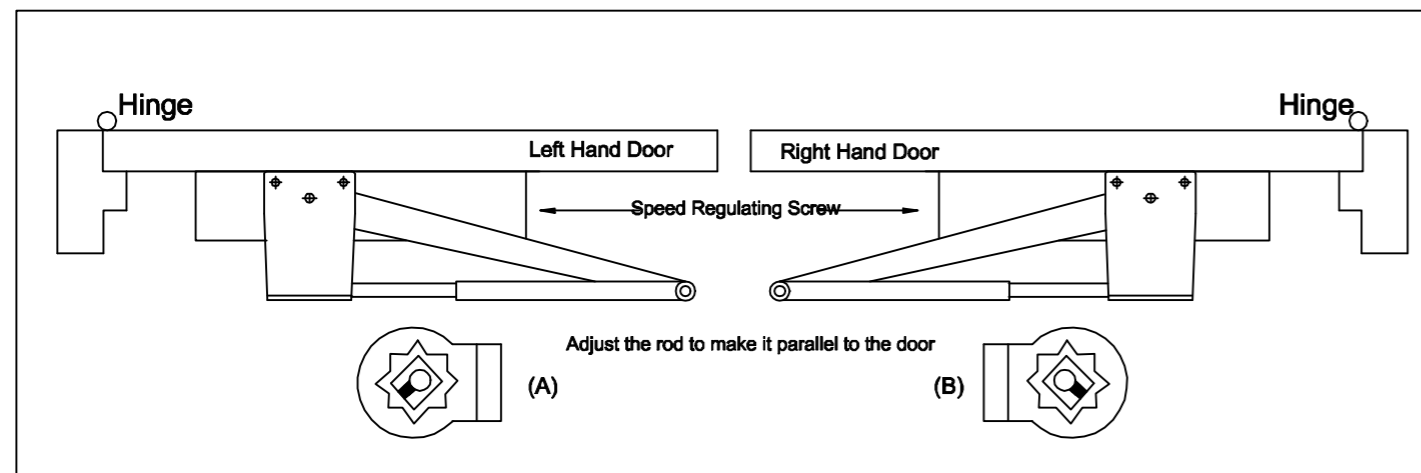

## ◆ Regular Arm Mounting

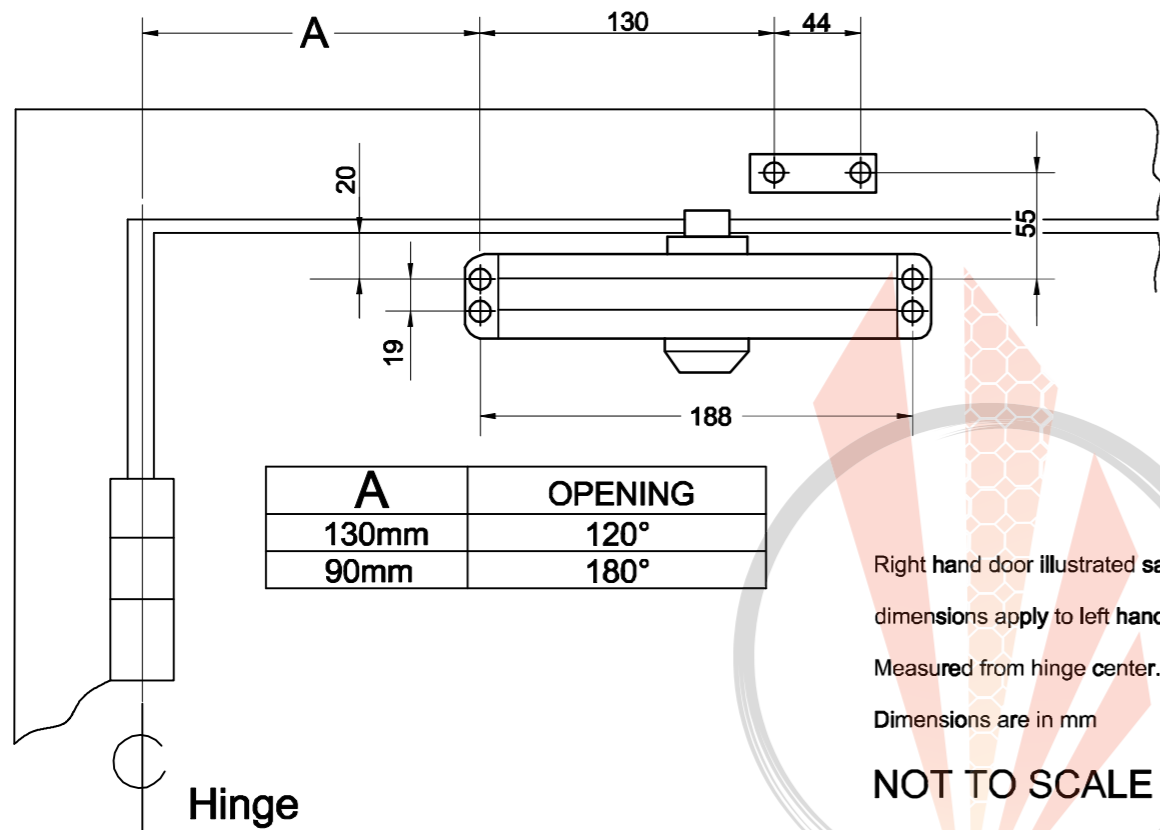

### Installation Sequences:

1. Selected opening degree of the door. Drill mounting holes on door leaf and frame in accordance with above shown dimensions.
2. Assemble main arm to closer pinion spindle.
3. Mount the door closer body to door leaf with speed regulating valve back to hinge.
4. Attach the foot and rod to the door frame.
5. Adjust length of forearm to make it perpendicular to frame when assembled to preloaded main arm. Secure pivot connection with screw and washer provided. Tighten locknut.
6. Snap pinion cap over shaft at the bottom of closer.

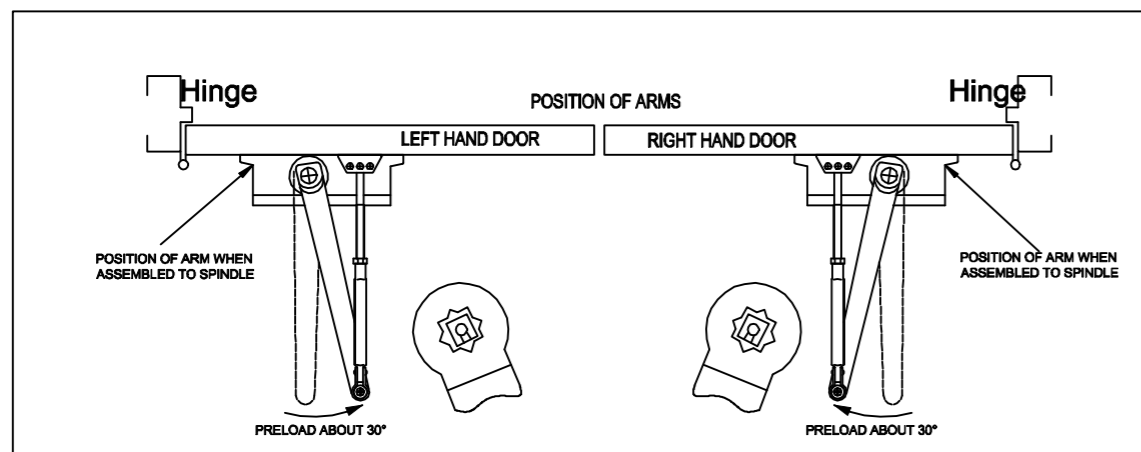

## ◆ Top Jamb Mounting

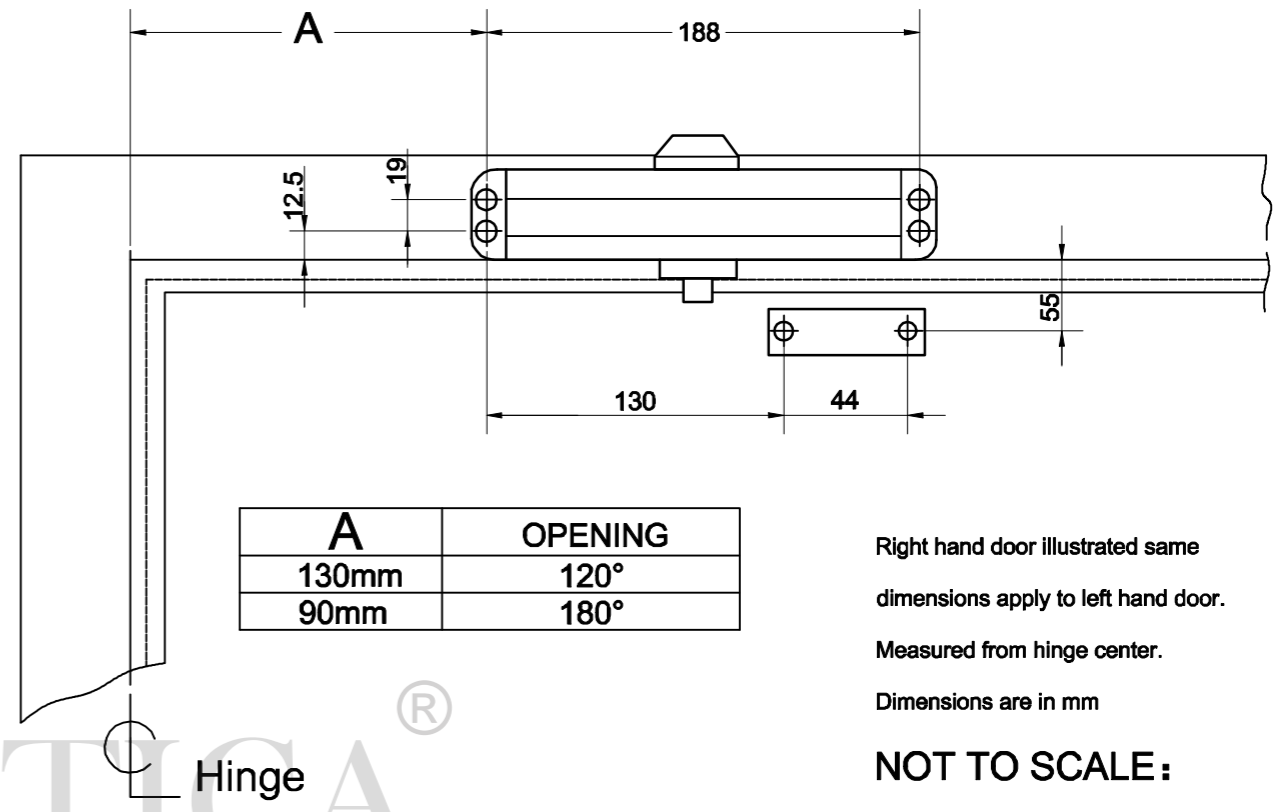

### Installation Sequences:

1. Selected opening degree of the door. Drill mounting holes on door leaf and frame in accordance with above shown dimensions.
2. Assemble main arm to closer pinion spindle.
3. Mount the door closer body to door leaf with speed regulating valve back to hinge.
4. Attach the foot and rod to the door frame.
5. Adjust length of forearm to make it perpendicular to frame when assembled to preloaded main arm. Secure pivot connection with screw and washer provided. Tighten locknut.
6. Snap pinion cap over shaft on the top of closer.

